



**EASA**  
European Aviation Safety Agency

# RMT 0599 Competency and evidence based training

Eric Bennett & Francisco Arenas Alvariño  
Project manager RMT0599  
Air Operations & Air Crew Regulation Officers  
Flight Standards Directorate

**Your safety is our mission.**

An agency of the European Union 

TE.GEN.00409-001



# Who is affected??

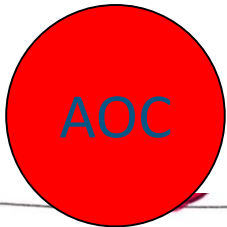

**ORGANISATIONS**



**AUTHORITY**





# EBT is not mandatory

- The prescriptive training and checking requirements will remain for those who can't to do EBT, or don't want EBT.





## NPA to be published Q1 2018

### ➤ Main features :

- Multi pilot operations of single pilot certified helicopters
- Recurrent checking requirements
- Operations on several helicopter types
- Other changes :
  - CRM,
  - aerodrome competency,
  - qualification to fly in either pilots seat...



# Summary of EBT (yesterday's EBT presentation)

- EBT is addressing the operational risks – Data report
  - Note: not all the risks can be mitigated through training
- Pilot's resilience
- Evidence based training means evidences from:
  - Regulator – data report
  - Operator – EBT system + Management system
  - Instructor – Evaluation on 1<sup>st</sup> day - Scenario Based training on the 2<sup>nd</sup> day
- Instructors: training – concordance – standardisation



# Evidence based training.

Legacy  
Pre-2008

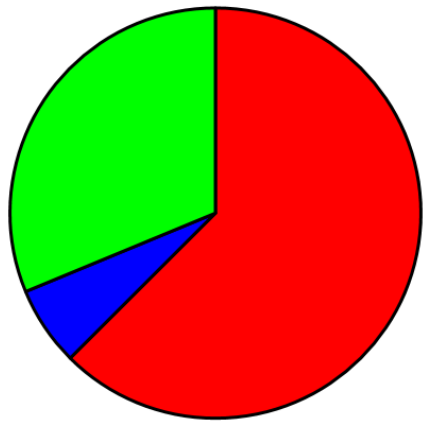

•ATQP  
2008

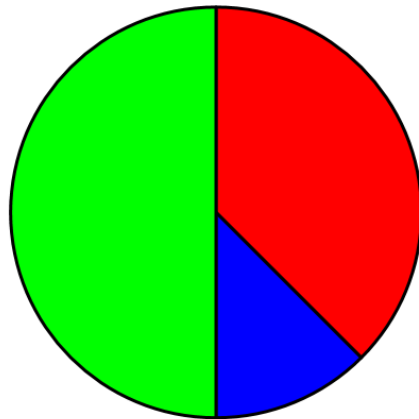

•Mixed  
2017

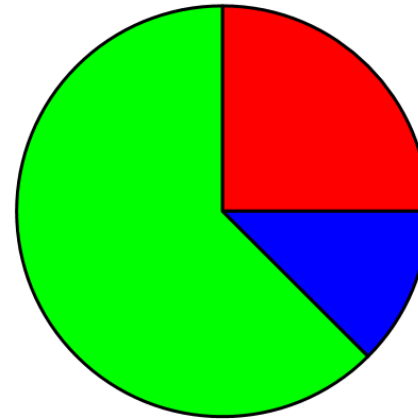

•EBT  
2019

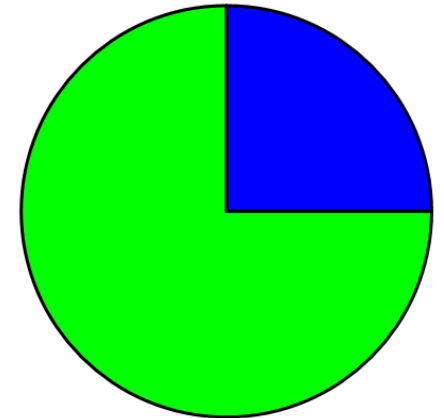

•Tests

•Sim hours per pilot per year

• LOFT/LOE/Eval

•Training



# EBT : A global approach to pilot training

Procedure to add new aircrafts

•Single philosophy of training for the operator

SPA

•Single philosophy of training across the industry

Operator  
Recurrent training

TRI courses

Interface RMT0196 CS-FSTD

Interface RMT0596

Review of subpart J&K

Interface RMT0379 AWO





# EBT is based on Pilot competencies

Pending the conclusions of the data report :

- Application of Procedures
- Communication
- Flight Path Management – Automation
- Flight Path Management – Manual Control
- Knowledge (not used in ICAO doc 9995 aeroplanes)
- Leadership and Teamwork
- Problem-solving and Decision-making
- Situation Awareness
- Workload Management
- Monitoring (not used in ICAO doc 9995 aeroplanes or in EASA aeroplane EBT)





# EBT helicopter generations list

➤ Helicopter generations have been defined for the purpose of EBT.

- with only crew training in mind
- For existing and future helicopters

Generation 1a / 1b	Current single piston or turbine engine <b>Analog / digital</b>
<b>Generation 2</b>	Twin turbine, non-FADEC controlled, analogue instrument display, basic AFCS (up to 3 axis)
<b>Generation 3a</b>	Twin turbine, FADEC, digital instrument display, navigation display, <b>full authority AFCS (4 axis)</b> , FMS
<b>Generation 3b</b>	All of Generation 3a characteristics, plus <b>envelope protection</b>

<b>Generation 4</b>	Twin turbine, FADEC, digital cockpit display, FMS, full authority AFCS, envelope protection, <b>fly-by-wire</b>
-------------------------	--------------------------------------------------------------------------------------------------------------------------



- ToR 0599 (Jan 2016) +
  - Consulted in Dec 2015
- Concept paper (Jan 2016) +
- Group composition (Jan 2016)
  - 32 people: Europe + USA + Middle east.
  - Authority + Airlines + ATO + Pilots + EASA.
  - Aeorplane groups and a Helicopter group





# Transition to EBT. Doc 9995 ICAO.

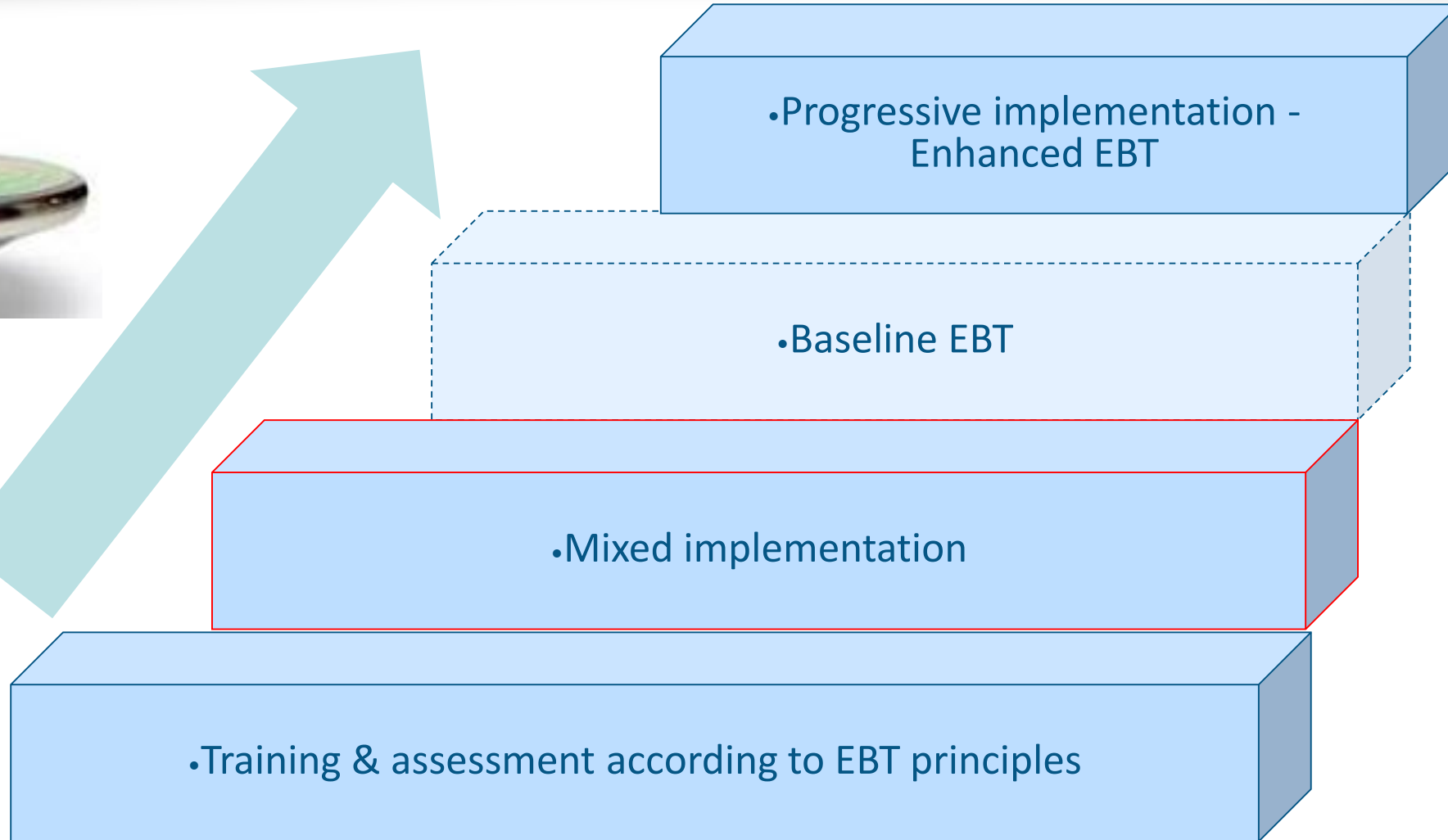
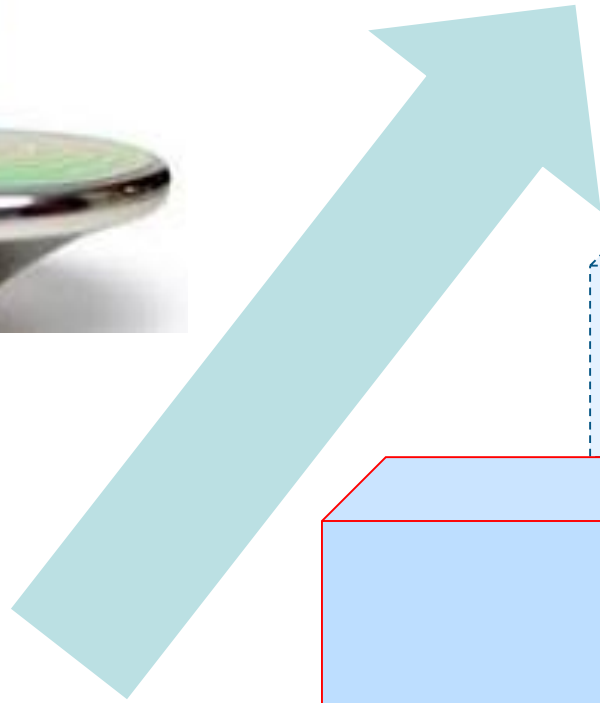
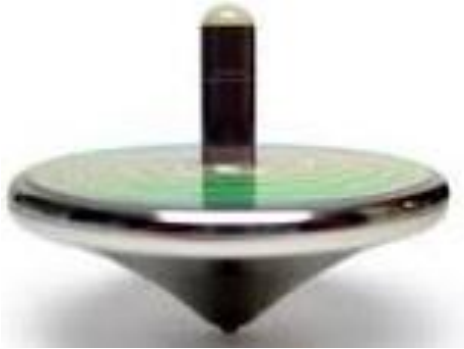



# What next?

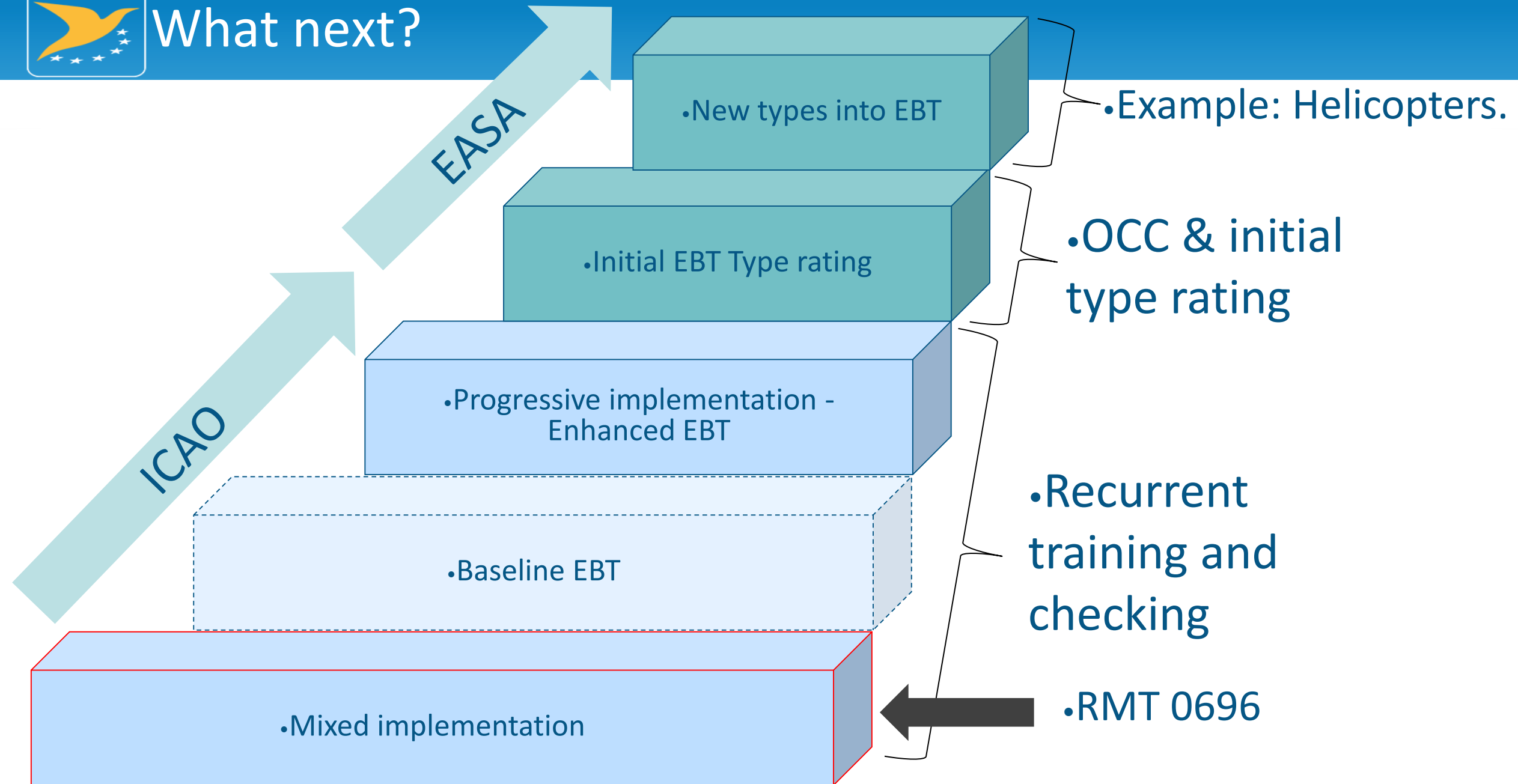



# Blended learning solutions

- Concept paper 1<sup>st</sup> draft available
- Presentation Workshop 01.02.2017
- Final concept paper NPA RMT0599 -1Q2018
- Regulatory road map:
  - Based on the blended learning principle
  - 1<sup>st</sup> Category C Aerodrome recency AMC ORO.FC.105 paragraph (c)
  - 2<sup>nd</sup> Partner selected – Norway NAA + SAS
  - 3<sup>rd</sup> 360 - Virtual reality video recorder in SAS facility 01.12.2017
  - 4<sup>th</sup> Study will be made by NLR until 2Q2018
  - 5<sup>th</sup> Results and possible amendment of AMC ORO.FC.105 (c) late 2018-2019





# Quick project overview - NPA

ToR

PHASE 1 - 2018

PHASE 2 – Mid 2020

PHASE 3 - 2022



EBT: OPC/LPC + SPA

Helicopters EBT:

Concept paper DATA report

Blended learning solutions: Concept Paper

NCC:AMC/GM ORO.FC Sec 1

•workshop

EBT: OCC+ Initial type rating

Helicopters EBT:

Data report for EBT (Helicopters)

Blended learning solutions: NPA

EBT: new types into EBT (Helicopters + Business jets)

Helicopters EBT:

Regulation

Blended learning solutions: Regulation

Aeroplanes: other implementation issues

Helicopters: other implementation issues



# When Regulations will be ready to use??

ToR

PHASE 1 - 2020

PHASE 2 – Mid 2022

PHASE 3 - 2023



EBT: OPC/LPC + SPA

Helicopters EBT:

Data report Concept paper

Alt training means & methods: Concept Paper

NCC:AMC/GM ORO.FC Sec 1

EBT: OCC+ Initial type rating

Helicopters EBT:

Data report for EBT helicopters

Alt training means & methods: NPA

EBT: new types into EBT  
(Helicopters + Business jets)

Helicopters EBT:

Regulation

Alt training means & methods: Regulation

Aeroplanes: other implementation issues (see master task list)

Helicopters: other implementation issues (see master task list)



**EASA**  
European Aviation Safety Agency

**END**



**Your safety is our mission.**

An agency of the European Union 





# RMT0599 Project overview – (Deliverables)

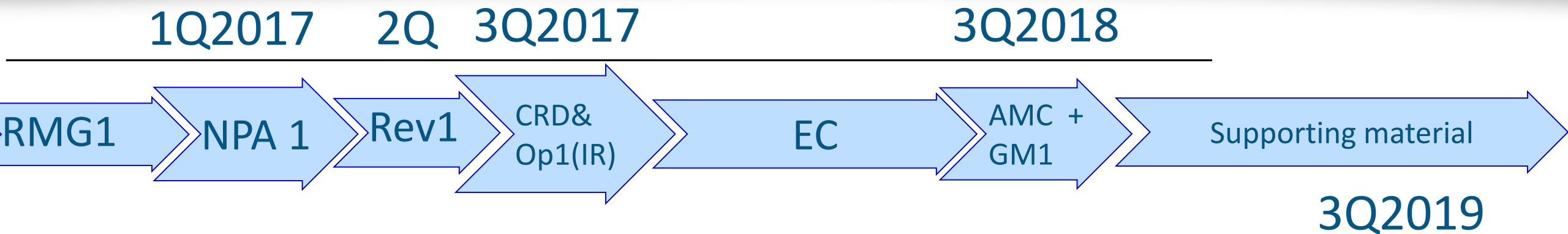

- EBT baseline implementation: First draft Sept 2016 – NPA planned 1Q2017.
- Concept paper on “Alternative training means” – 1Q 2017.
- EBT Mixed implementation. Checklist for operators & authority – 1Q2017.
- Workshop EBT & RMT0599 – February 2017.
- AMC/GM to ORO.FC section 1 NCC operators – 1Q2017.
- Helicopters – Data report for EBT helicopters – 1Q2017.
- Helicopters – Improvement of the regulation – 1Q2017.



# Why we are discussing Alternative training means

- ▶ AMC1 ORO.FC.230 (a)(4)(i)(A) [training in FSTD all major failures of aircraft systems].
- ▶ New technologies available in the industry
- ▶ New training methodologies available
- ▶ Provide guidance below the ICAO doc 9625



# Alternative training means

- Concept paper 1<sup>st</sup> draft available
- Presentation on the 19.10.2016
- Workshop 20.10.2016 and 01.02.2017
- Regulatory road map:
  - Based on the blended learning principle
  - 1<sup>st</sup> Define the characteristics of each alternative training means
  - 2<sup>nd</sup> Extract all the training requirements in the regulation
  - 3<sup>rd</sup> Define for each training requirements which characteristics are needed
  - 4<sup>th</sup> See which training requirements can be done in alternative training mean





# Transition to EBT. Doc 9995 ICAO.

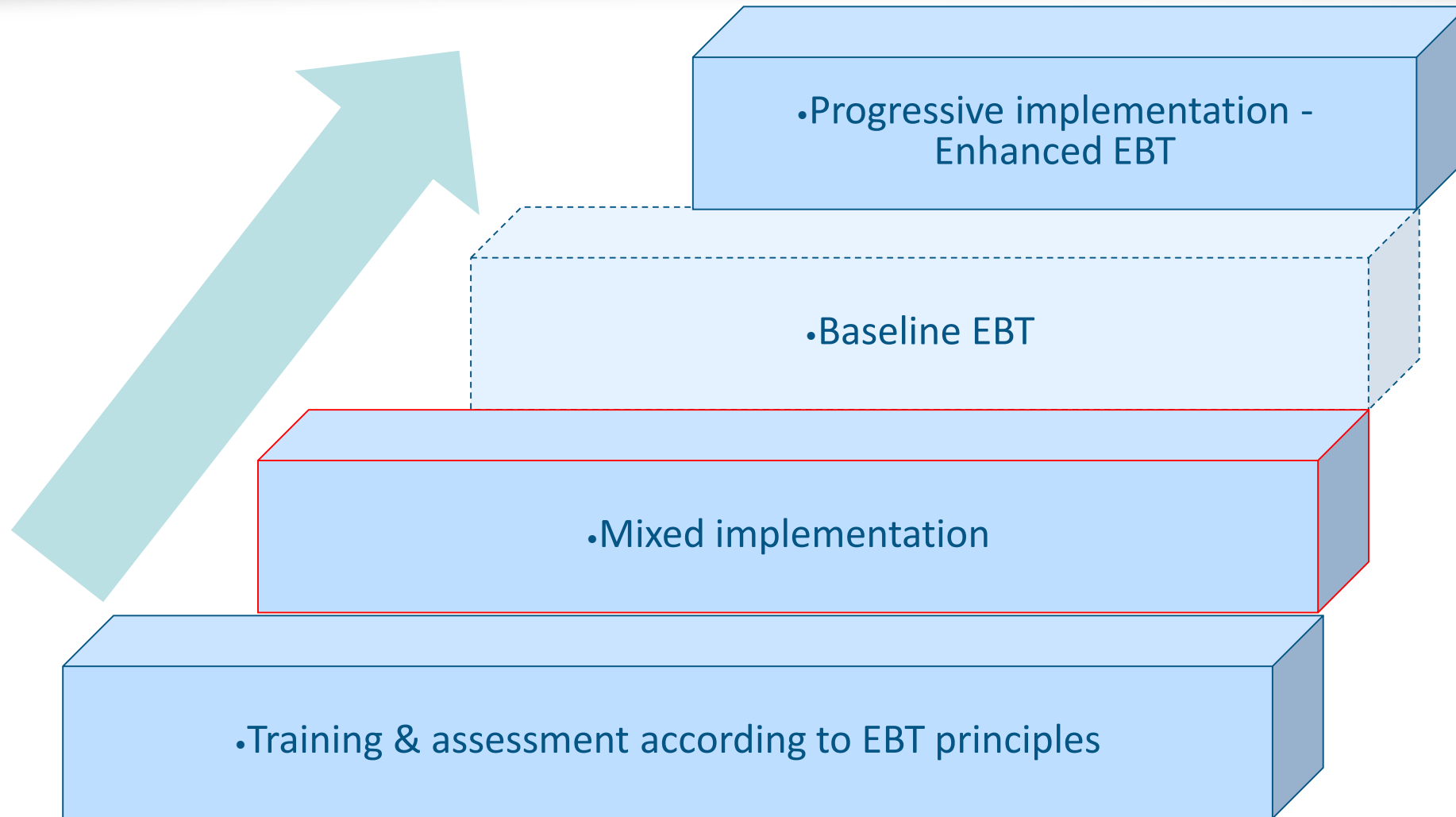



# Background: mixed implementation

- RMT0696 Implementation of evidence-based training (EBT) within the European regulatory framework.
  - Task force created in July 2015
  - ToR published in Sept 2015
  - Focus consultation in Sept 2015
  - Decision 2015/027/R published in Dec 2015.
    - Competency – Knowledge can be found in the explanatory note
  
- Mixed EBT implementation



# Supporting material to RMT0696

- 1- Explanatory note to ED Decision 2015/027/R (Dec 2016)
- 2- ICAO Doc 9995
- 3- IATA EBT implementation guide
- 4- Transition to EBT EASA checklist (To be published in 3Q2016) currently under consultation in Standardisation network.



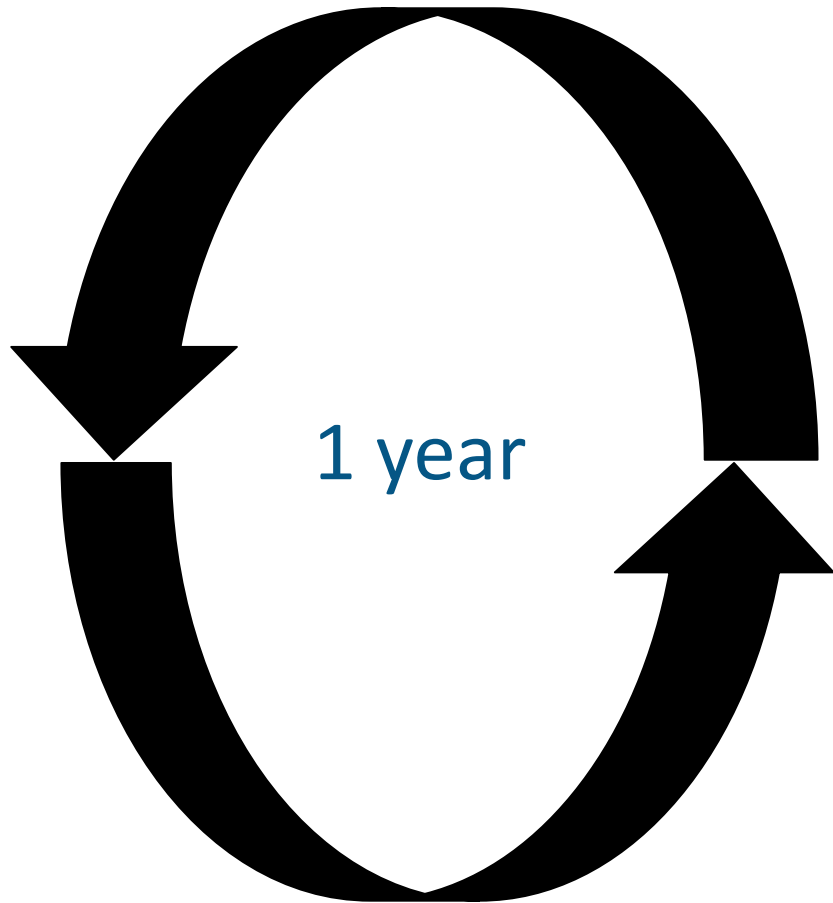

- ToR : Sept 2015
- ED decision : Dec 2015
- Supporting material
  - Explanatory note to the ED decision
  - EBT Checklist: Sept 2016.



# What next?

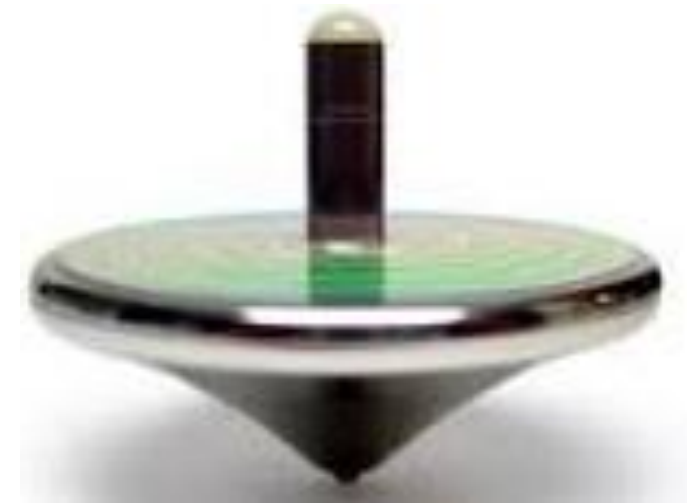
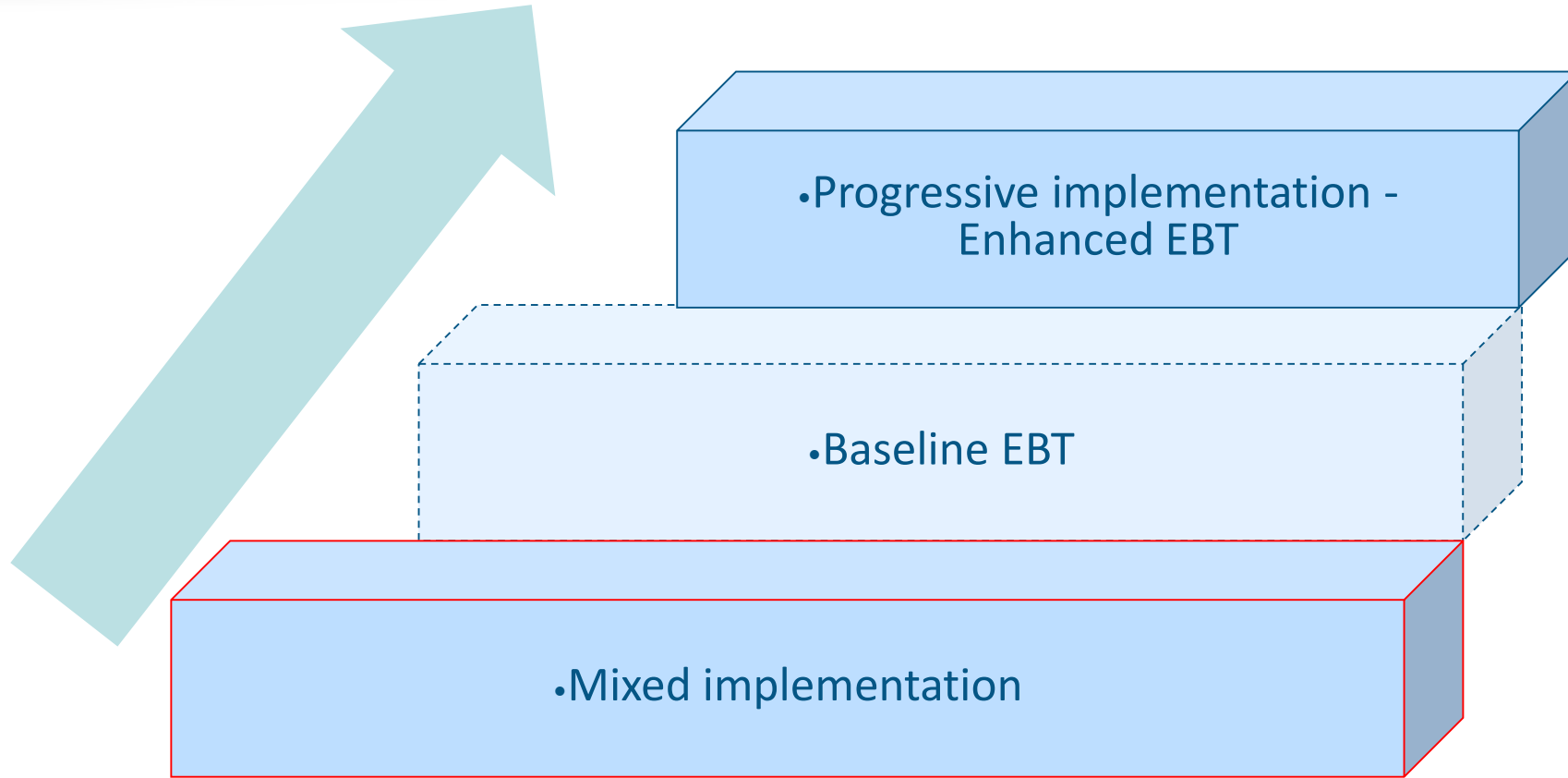





## RMT 0599: Review of ORO.FC

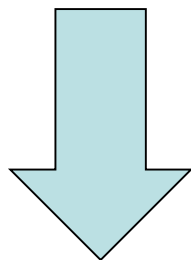

•RMT0696

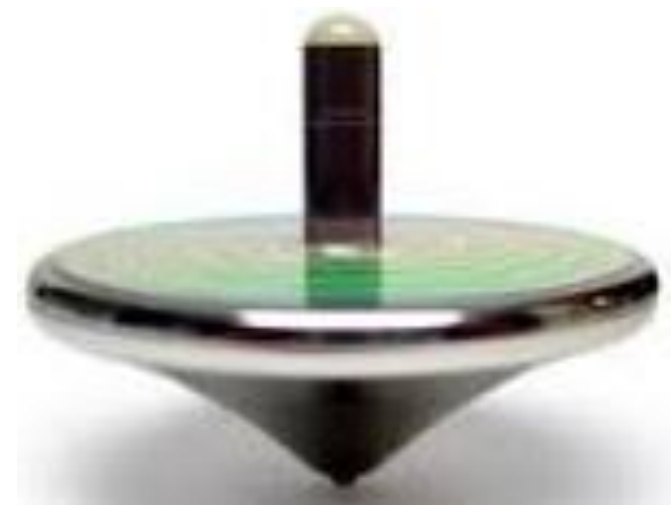



- Complex task: full review of ORO.FC
  - The review will include direct and indirect impact
- ToR 0599 (Jan 2016) +
  - Consulted in Dec 2015
- Concept paper (Jan 2016) +
- Group composition (Jan 2016)
  - 32 people: Europe + USA + Middle east.
  - Authority + Airlines + ATO + Pilots + EASA.





# What next?

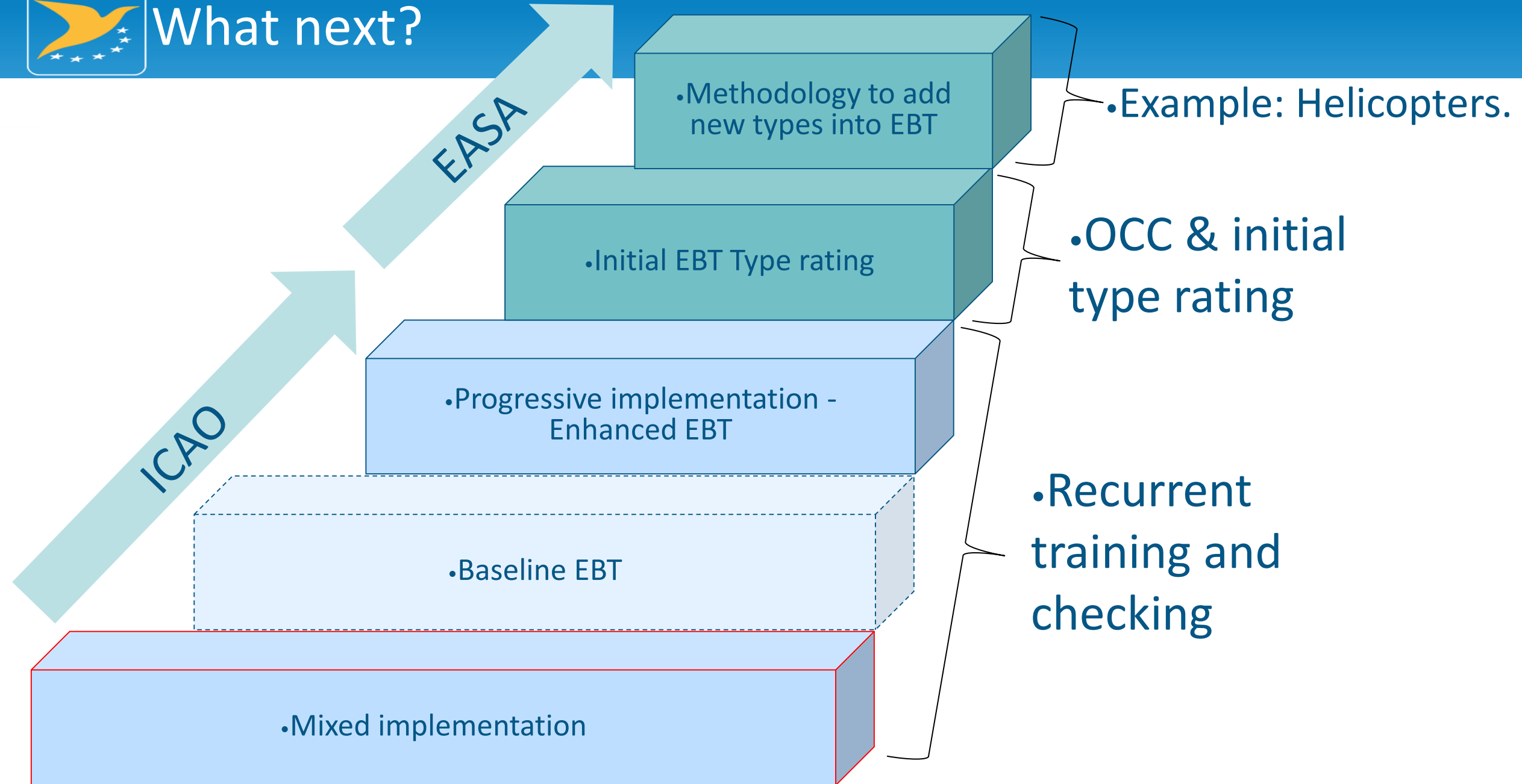



# Operator centric: Review of ORO.FC

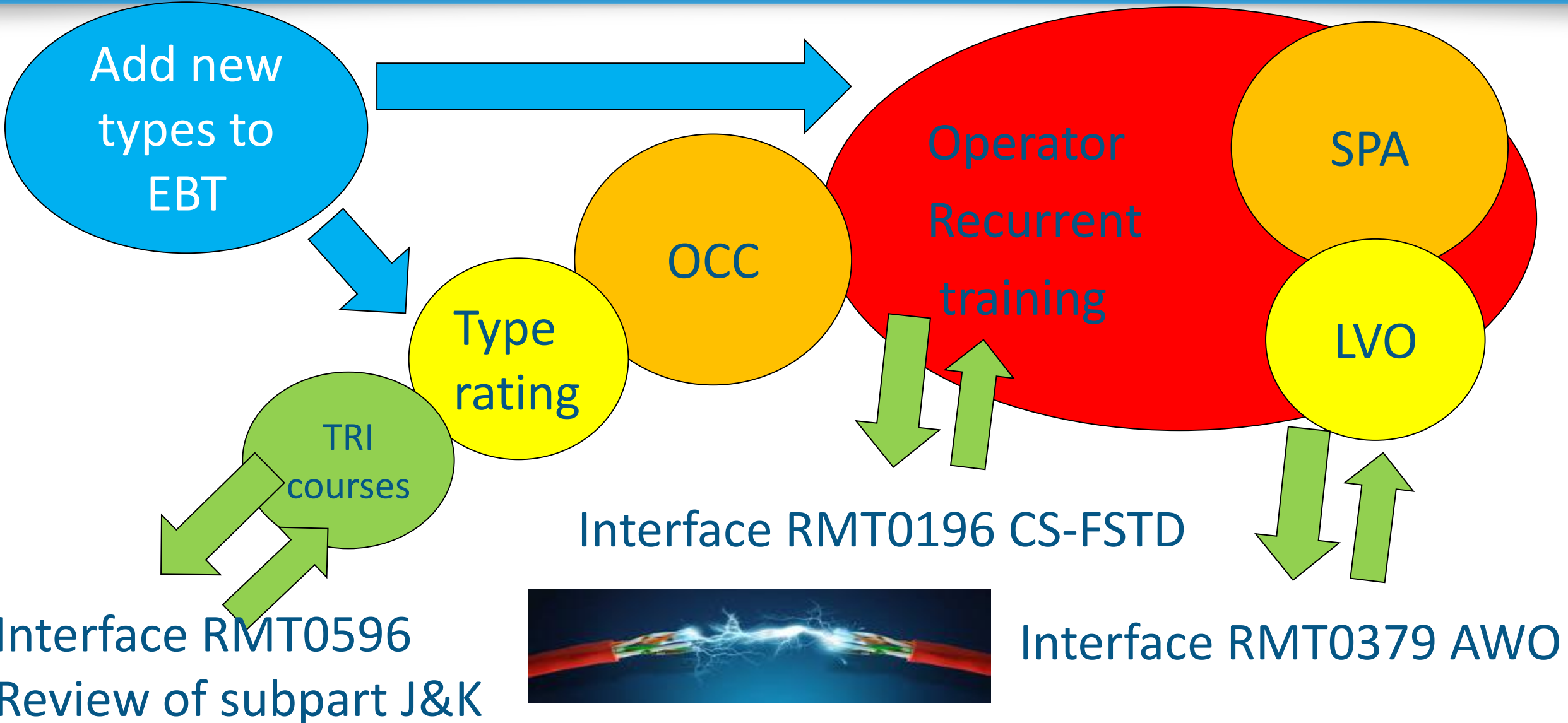

Interface RMT0596  
Review of subpart J&K





# Who is affected??



AOC

ORGANISATIONS

ATO



**AUTHORITY**



# Quick project overview - NPA -

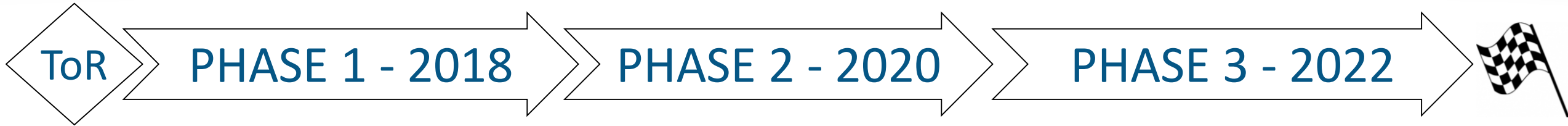

**EBT:** OPC/LPC + SPA

**EBT:** instructor training

Concept paper CB Training

**NCC:** AMC & GM

ORO.FC section 1

**EBT:** OCC+ Initial type rating

**EBT** TRI/TRE qualification

Concept paper CB Training

**EBT:** Methodology to add new types into EBT (Helicopters + Business jets)

## Interoperability

**Aeroplanes:** implementation issues (see master task list)

**Helicopters:** implementation issues (see master task list)

**Helicopters:** EBT



## The RMG.0599 is composed of:

- As described in the ToR, RMG is composed of 3 groups:
  1. a main subgroup:
    - addressing issues described in this ToR, not related to EBT or helicopters;
    - Un bias EBT subgroup related material;
  2. a EBT subgroup: EBT-related issues; and
  3. a Helicopter subgroup: helicopter training-related issues, including EBT and extension of ATQP to helicopters.



# RMT0599 Project overview

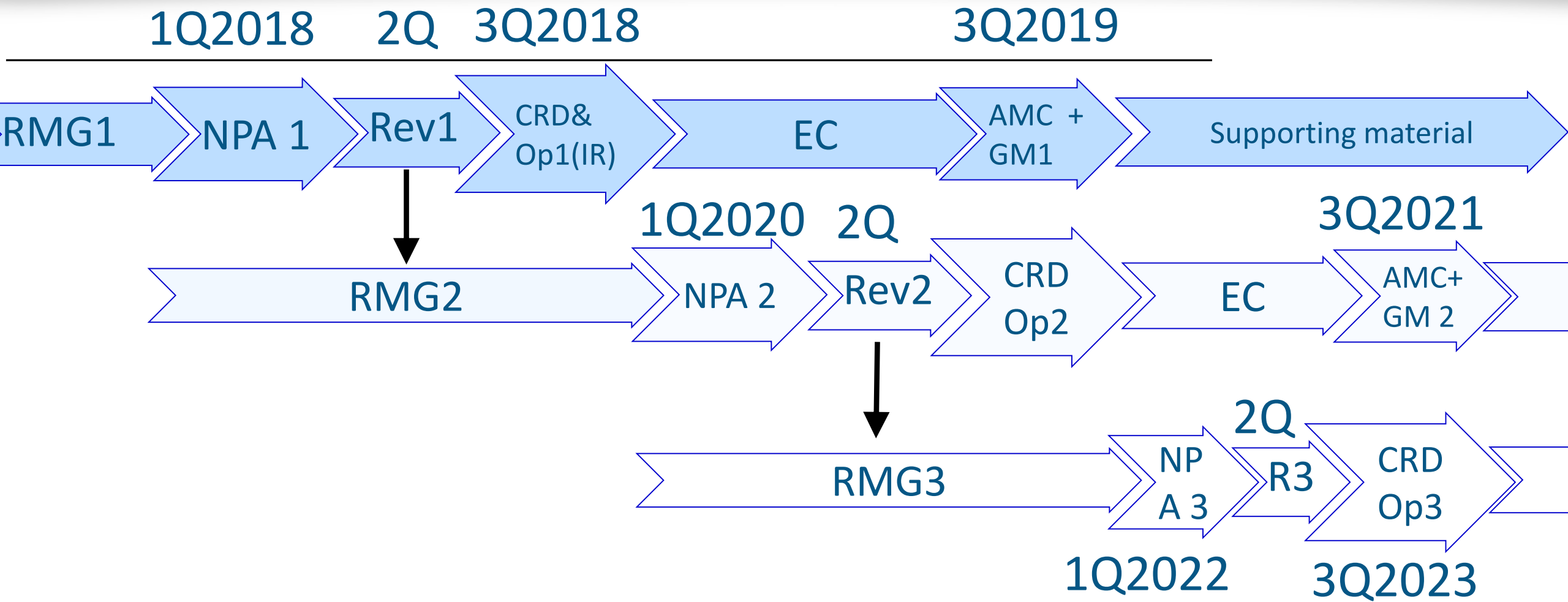





- Annex I definitions
  - Both IR and GM to definitions
- ORO.FC.A.2XX Leading statement plus list of alleviations from other provisions (SPA.LVO.120 + ORO.FC.230 ...etc)
  - ORO.FC.2XX Competencies, Grading system
  - ORO.FC.2XX Baseline program
  - ORO.FC.2XX Equivalence of malfunctions and approach types
  - AMC ORO.FC.145? Instructor training
- FCL.740.A Revalidation of type rating
- AMC SPA.LVO.120 (approach clustering AWO-LVO)



**EASA**  
European Aviation Safety Agency

**END**



**Your safety is our mission.**

An agency of the European Union 